



**COUNTY OF LAKE**  
**Department of Health Services**  
**Environmental Health Division**  
 922 Bevins Court, Lakeport, CA 95453  
 Ph (707) 263-1164 / Fax (707) 263-1681



**TEMPORARY FOOD FACILITY PERMIT APPLICATION**

Please submit application fourteen (14) business days before the event to allow for processing. To encourage early processing, a 10% discount will be given to those who submit application package at least ten (10) business days before the event. Applications received within three (3) business days of event **may or may not** be approved. A double fee will be assessed for operating without a permit at an event.

Name of Event:					Location:					
Dates of Operation:			Thru:			Event Start Time:			Event End Time:	
Name of Booth/Concession:						Booth Start Time:				
Owner/Operator:				Day Phone:				Email:		
Mailing Address:						City, Zip				
Non-Profit Charitable Organization?	<input type="checkbox"/> Yes <input type="checkbox"/> No		If yes, provide required documentation							
Requesting a veteran exemption? If yes, provide required documentation	<input type="checkbox"/> Yes <input type="checkbox"/> No		Are you a permitted facility in Lake Co.?		<input type="checkbox"/> Yes <input type="checkbox"/> No					
Facility Type:	<input type="checkbox"/> Booth	<input type="checkbox"/> Permanent building	<input type="checkbox"/> Food Cart	<input type="checkbox"/> Mobile Food Truck/Trailer						
Where is food being prepared?	<b>HOME PREPARATION IS NOT ALLOWED</b>									
<input type="checkbox"/> Onsite:	<input type="checkbox"/> Booth	<input type="checkbox"/> Cart	<input type="checkbox"/> Mobile							
<input type="checkbox"/> Commissary (1-Provide location and attach health permit if outside Lake County; 2-Please provide commissary agreement –see attached).										
<input type="checkbox"/> Cottage Food Operation (Provide permit and county name if other than Lake).										
<input type="checkbox"/> Caterer (Please attach health permit and copy of commissary agreement).										
<input type="checkbox"/> Other (Please describe)										
<b><i>This application submittal shall include:</i></b>										
<input type="checkbox"/> Completed and signed application with fee (check made payable to County of Lake)										
<input type="checkbox"/> Food booth layout										
<input type="checkbox"/> Food and beverage plan (attached Menu Sheet must be completed)										
<input type="checkbox"/> Veteran's and Non-Profit Organization Exemption documentation (if applicable)										
<b>Operator's declaration: I have read and will comply with the Temporary Food Facility Requirements and I fully understand that any deviation from the submitted application without prior approval may nullify final approval.</b>										
Signature of Operator:						Date:				

**Office Use Only:**

Date Rcvd:	Fee Paid:	Receipt No.:	Facility ID No.:	PE Code:	Program No.:
Approved by Specialist:					Date:



# BOOTH DRAWING

All booth vendors shall complete this section *including* those selling or serving prepackaged food.

In the space below, provide a drawing of your booth. Identify and describe all equipment, including cooking and holding equipment, handwashing facilities, work tables, utensil washing sink (containers), food and paper product storage, garbage containers, and customer service areas (see sample below).

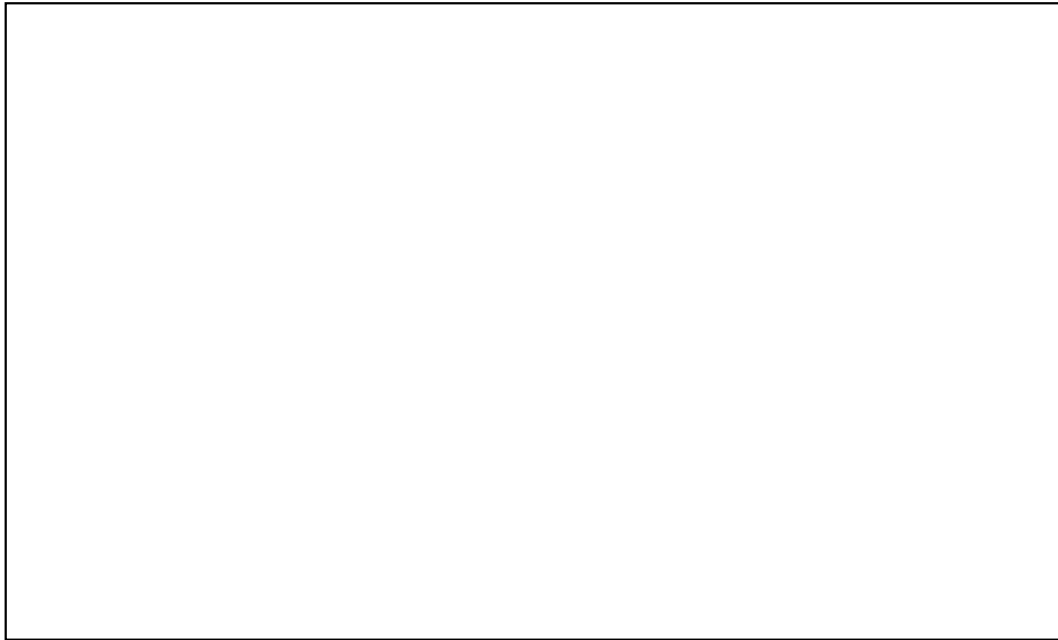

-10'-

-10'-

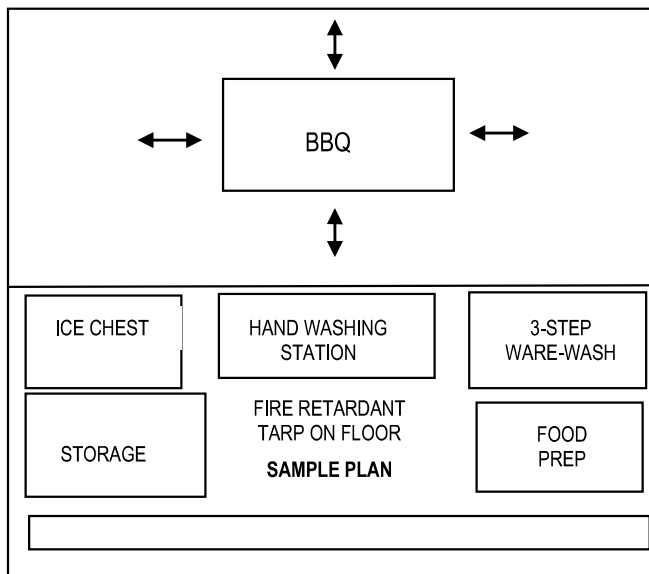

Cooking equipment allowed outside but adjacent to booth: Open air BBQ and cooler for storage of raw meat at the grill, large open flame equipment using propane tanks. **BBQ grills must be properly secured from public access (ex: rope, chain, etc.) to prevent contamination of FOOD and injury to the public.**

Barbecues, grills or other EQUIPMENT APPROVED for outdoor cooking may be located adjacent to the TEMPORARY FOOD FACILITY if local building and fire codes prohibit cooking inside the TEMPORARY FOOD FACILITY.



**COUNTY OF LAKE**  
**Department of Health Services**  
**Environmental Health Division**  
922 Bevins Court, Lakeport, CA 95453  
Ph (707) 263-1164 / Fax (707) 263-1681



**If you are hiring a caterer, please complete this section:**

Name of catering business:			
Owner's name:		Phone Number:	
Caterer's Lake County Permit #:			

---

Will food be prepared or stored off-site prior to the event? Yes No

Commissary Agreement attached: Yes No

If yes, a Commissary Agreement ***must be submitted with this application.***



**COUNTY OF LAKE**  
**Department of Health Services**  
**Environmental Health Division**  
 922 Bevins Court, Lakeport, CA 95453  
 Ph (707) 263-1164 / Fax (707) 263-1681



**COMMISSARY AGREEMENT**

Please complete Sections 1 and 2. If your commissary is outside of Lake County please also complete Section 3.

**Section 1 – To be completed by APPLICANT**

Business Name:						PR#	
Owner/Operator Name							
Business Mailing Address:						Suite	
City:		State:		Zip:		Home Ph:	
						Bus. Ph:	

I, \_\_\_\_\_, hereby state that the above information is current, true and correct to the best of my knowledge and agree to utilize my approved commissary in accordance with the California Health & Safety Code, California Retail Food Code, and Lake County Ordinances, requirements. **Note: if this Commissary Agreement is modified or cancelled, and a new Commissary Agreement is not provided to this office, your permit to operate a food facility will be subject to suspension or revocation. This Commissary Agreement shall be effective for no longer than one year.**

Signature: \_\_\_\_\_ Date: \_\_\_\_\_

**Section 2 – To be completed by Commissary Owner/Operator**

Commissary Name:						PR#	
Address:						Bus Phone:	
City:		State:		Zip:		Owner/Operator:	
Check all appropriate services provided:							
<input type="checkbox"/> Wastewater Disposal		<input type="checkbox"/> Food preparation area		<input type="checkbox"/> Refrigeration equipment			
<input type="checkbox"/> Potable Water		<input type="checkbox"/> Electrical hookups		<input type="checkbox"/> Food storage facilities			
<input type="checkbox"/> Disposal of rubbish and garbage		<input type="checkbox"/> Toilet & handwashing facilities		<input type="checkbox"/> Janitorial sink			
<input type="checkbox"/> Hot and cold water for vehicle cleaning		<input type="checkbox"/> 3-compartment sink		<input type="checkbox"/> Overnight vehicle storage			
<input type="checkbox"/> Other services not listed:							

I, \_\_\_\_\_, hereby state that the information I have provided is current, true and correct to the best of my knowledge and meets the California Health and Safety Code requirements. If the food facility operator fails to comply with the conditions of this contract, or if this contract is modified or cancelled, the commissary owner shall notify this office immediately.

Signature: \_\_\_\_\_ Print Name: \_\_\_\_\_ Date: \_\_\_\_\_

**Section 3 – To be completed by Environmental Health jurisdiction outside of Lake County**

The commissary is located in \_\_\_\_\_ County. The above food facility meets the commissary requirements pursuant to CalCode Sections 114211, 114245.1, 114294 and 114326. The above checked services are available at the above commissary. Please notify the Lake County Department of Health, Environmental Health (707) 263-1164, should the status of this permit change or if it falls below acceptable CalCode standards.

REHS Signature:		Print Name:	
Date:		Business Phone:	



**COUNTY OF LAKE**  
**Department of Health Services**  
**Environmental Health Division**  
922 Bevins Court, Lakeport, CA 95453  
Ph (707) 263-1164 / Fax (707) 263-1681



### **COMMISSARIES SERVICING MOBILE FOOD FACILITIES IN LAKE COUNTY**

A commissary is a food establishment permitted by the Division of Environmental Health.

Sections 114295 and 114297 of the California Health and Safety Code (CHSC) requires that each mobile food facility and mobile food preparation unit shall operate out of a commissary. They shall report to the commissary at least once each operating day for cleaning and servicing operations. All Mobile Food units shall be properly stored, cleaned, and serviced at or within the commissary. No food may be stored or prepared at a private residence, garage or storage unit.

Approval from the Division of Environmental Health is based on the following:

- 1) Applicants shall obtain a letter from the Operator of a Commissary stating his/her willingness to allow the applicant to utilize the Commissary on a daily basis for:
  - a) Storage of food and dry goods
  - b) Filling of potable water tanks and disposal of wastewater
  - c) Necessary food preparation
  - d) Necessary cleaning and sanitizing of utensils
  - e) Cleaning and servicing of unit
  - f) Storage of unit
- 2) The Health Inspector will visit the proposed commissary to verify that dedicated storage is available to the Applicant.
  - a) The necessary storage is based on the size of the unit and the type of food preparation described in the operator's business plan. For example, a typical mobile food preparation unit requires 16 cubic feet of refrigerated storage and 16 cubic feet of dry storage.
  - b) The Health Inspector will verify during routine inspections that the permittee is utilizing the dedicated storage area.

Prior approval by the Division of Environmental Health is required if the permittee later desires to change commissaries.



**COUNTY OF LAKE**  
**Department of Health Services**  
**Environmental Health Division**  
 922 Bevins Court, Lakeport, CA 95453  
 Ph (707) 263-1164 / Fax (707) 263-1681



## APPLICANT TO KEEP THIS FORM

### FOOD FACILITY (TFF) SELF-INSPECTION CHECKLIST

**\*This checklist is to be completed and posted inside the booth during operation\***

CHECK LIST REQUIREMENTS		COMPLIES		
		YES	NO	N/A
<b>1</b>		<b>FOOD SOURCE AND TEMPERATURE</b>		
	<b>A</b>	<b>Source:</b> All food shall be obtained from a permitted commercial or retail food establishment.		
	<b>B</b>	<b>Preparation:</b> All food shall be stored and prepared at a permitted food establishment or within the permitted temporary food booth. Food stored or prepared at home or other unapproved location is prohibited. (*See TFF Packet for Nonprofit Charitable exemptions)		
	<b>C</b>	<b>Thawing:</b> Food shall be thawed in the refrigerator at 41°F or less, submerged in running water at 70°F or less, in a microwave, or as part of the cooking process.		
	<b>D</b>	<b>Holding Temperatures:</b> All foods requiring hot or cold holding to prevent growth of harmful bacteria have been identified. Potentially hazardous foods shall be maintained hot at 135°F or higher, or cold at 41°F or below. Holding temperatures are to be checked at opening & every 2 hours booth is in operation, must document temperatures on the Holding Temperatures Log.		
	<b>E</b>	<b>Cooking Temperatures:</b> Food shall be cooked to the minimum internal temperatures specified below: *165°F for 15 seconds for poultry, any stuffing containing fish, beef, pork or poultry, or stuffed fish, beef, pork or poultry. *155°F for 15 seconds for ground fish and ground meat (hamburgers) *145°F for 15 seconds for eggs or dishes containing raw egg, whole fish, and whole meat		
	<b>F</b>	<b>Reheating for Hot Holding:</b> Previously cooked, cooled, and reheated foods shall be reheated to an internal temperature of 165°F.		
	<b>G</b>	<b>Thermometer:</b> A probe thermometer with a temperature range of 0°F-220°F for measuring food holding and cooking temperatures is required.		
<b>2</b>		<b>PERSONNEL</b>		
	<b>A</b>	<b>Health:</b> All employees are healthy. Employees experiencing vomiting and/or diarrhea must be excluded from food related activities. Permit holder requires food employees to report illnesses as required. Employees with cuts or sores on their hands shall wear gloves in addition to proper handwashing.		
	<b>B</b>	<b>Handwashing:</b> Handwashing facilities shall be provided inside the booth (adequate potable warm water in a container with a spigot, with catch bucket for wastewater, soap and paper towels).		
	<b>C</b>	<b>Hygiene:</b> Food workers shall maintain personal cleanliness, wash hands frequently, wear clean clothing, and wear hair restraints		
	<b>D</b>	<b>Food Preparation:</b> Avoid bare hand contact with food. Whenever possible use gloves, tongs, deli paper, spatulas or other dispensing equipment when handling ready-to-eat foods. Change gloves often and wash hands in between changing gloves.		
<b>3</b>		<b>FOOD AND UTENSIL STORAGE AND HANDLING</b>		
	<b>A</b>	<b>Hot and Cold Holding:</b> Necessary equipment and supply to maintain proper food temperatures, 41°F or less for cold foods, 135°F or above for hot foods (i.e. a means of obtaining ice throughout the event, electricity and sufficient heating fuel).		
	<b>B</b>	<b>Storage:</b> All food and equipment (except BBQs) shall be stored inside the booth and at least 6 inches off the ground. Bulk items protected from contamination by a solid waterproof barrier may be stored on the ground (e.g. ice chest).		
	<b>C</b>	<b>Food Storage During Multiple Day Events:</b> During periods of non-operation, potentially hazardous foods shall be stored in a refrigerator at an approved location. All other food shall be stored in sealed containers inside a permitted food establishment. Location:		

**CHECK LIST REQUIREMENTS**

		YES	NO	N/A
D	<b>Customer Self-Service:</b> Condiments must be dispensed in single service type packaging, in pump-style dispensers, squeeze bottles, shakers, or similar dispensers.			
E	<b>Food Display:</b> All food shall be protected from customer handling, coughing, sneezing, or other contamination. All cooking and serving areas shall be protected from contamination. BBQs should be roped off or otherwise separated from the public. Food sampling shall be conducted in a sanitary manner (*see Sampling Guidelines).			
F	<b>Utensil Storage:</b> In-use food dispensing utensils must be stored in the food with their handles above the food. Wash and sanitize all utensils before storing. Store clean utensils in a sanitary location protected from contamination.			
G	<b>Cross Contamination:</b> Food shall be protected from cross contamination by separating raw animal foods from ready-to-eat foods during storage, slicing, preparation, holding, and display. Provide separate cutting boards, knives, and disposable gloves for handling raw meats, poultry or seafood.			
H	<b>Ice:</b> Ice used for refrigeration cannot be used for consumption.			
4	<b>CLEANING</b>			
A	<b>Ware washing:</b> Provide either a 3-basin set up or a three-compartment sink with potable hot running water for ware washing. Scrap dishes then 1. WASH, 2. CLEAN WATER RINSE, 3. SANITIZING SOAK. Use approved sanitizing tablets or use bleach at 1 tablespoon per gallon of rinsing water. Change water often.			
B	<b>Wiping Cloths:</b> Wiping cloths for food contact surfaces shall be used once then laundered or thrown away, or shall be stored in a clean sanitizing solution of proper concentration between uses. Change sanitizing solution often.			
5	<b>WATER SUPPLY AND WASTEWATER DISPOSAL</b>			
A	<b>Water:</b> An adequate supply of <b>warm and cold</b> potable water shall be available on site for cooking, cleaning, sanitizing, handwashing and drinking. Potable water includes bottled water, water from an approved public water supply, and water from an approved private water supply. Water supply hoses must be made from food grade materials (garden hoses are prohibited).			
B	<b>Wastewater Disposal:</b> Wastewater will be disposed of in an approved wastewater disposal system (e.g., in a sink or toilet) located at _____. Wastewater may not be dumped onto the ground surface, into waterways, or into storm drains.			
6	<b>PREMISES</b>			
A	<b>Garbage:</b> Leak-proof and insect-proof garbage containers with plastic garbage bags shall be provided.			
B	<b>Waste Grease:</b> Waste grease shall be disposed of into a serviceable tallow bin or in another approved manner.			
C	<b>Lighting:</b> Adequate lighting shall be provided.			
D	<b>Animals:</b> No live animals are permitted in or within 20 feet of facility.			
7	<b>FOOD BOOTH</b>			
A	<b>Identification:</b> Facility name, operator name, city, state and zip code shall be posted in a location clearly visible to patrons. Display Health Permit.			
B	<b>Tables, Counters and Shelves:</b> Tables, counters, food prep surfaces, and shelves shall be smooth, easily cleanable and nonabsorbent.			
C	<b>Enclosure:</b> Booth shall consist of four complete sides and a top (plywood, canvas, plastic or fine mesh fly screen) and shall enclose all food and equipment. Note: Local Fire Dept may require proof of fire retardant materials.			
D	<b>Floor:</b> Cleanable floor surfaces (tarp or other cleanable material) shall be provided.			
E	<b>Access Doors and Pass-thru Windows:</b> Tight-fitting closures for access doors openings are required. Pass-thru windows are closeable and not larger than 18" X 12".			

**NOTE: This list may not include all the necessary equipment you will need for your individual operation. Please contact Environmental Health at (707) 263-1164 for questions on equipment requirements.**

**I have provided all of the above for the operation of my food booth. I understand that failure to provide all of the above items may result in immediate closure of my booth. I understand that I must post this completed checklist inside my booth.**

Signed: \_\_\_\_\_

Date: \_\_\_\_\_





**Avoid Foodborne Illness-Avoid the Danger Zone:** Bacteria will grow very quickly on foods held in the danger zone. The danger zone is above 41°F and below 135°F. Bacteria on foods can cause illness or death. Protect your customers by checking food temperatures often.

**Minimum Cooking Temperatures of Food (internal temperatures)**

Poultry and foods containing poultry	165° F
Stuffed fish, meats, or poultry	165° F
Grounds meats (i.e. hamburger)	155° F
Eggs (to be hot held)	155° F
Fish	145° F
Single pieces of meat	145° F
Eggs (cooked to order)	145° F
All other potentially hazardous foods (i.e. cooked vegetables)	140° F



Use a probe thermometer to check food temperatures

Reheating Temperature for PHFs: 165° F Hot Holding

Temperature for PHFs: 135° F Cold Holding

Temperature for PHFs: 41° F\*



\*During operating hours of a Temporary Food Facility, a serving line, or a salad bar PHFs may be held at a temperature not to exceed 45° F for up to 12 hours in any 24-hour period. At the end of the operating day any PHFs held at 45° F must be discarded.

\*Raw shell eggs, unshucked live molluscan shellfish, pasteurized milk and pasteurized milk products in original sealed containers, and PHFs held for sampling at Certified Farmers' Markets may be cold held at 45°

# FOOD PREPARATION TEMPORARY HAND WASHING STATION

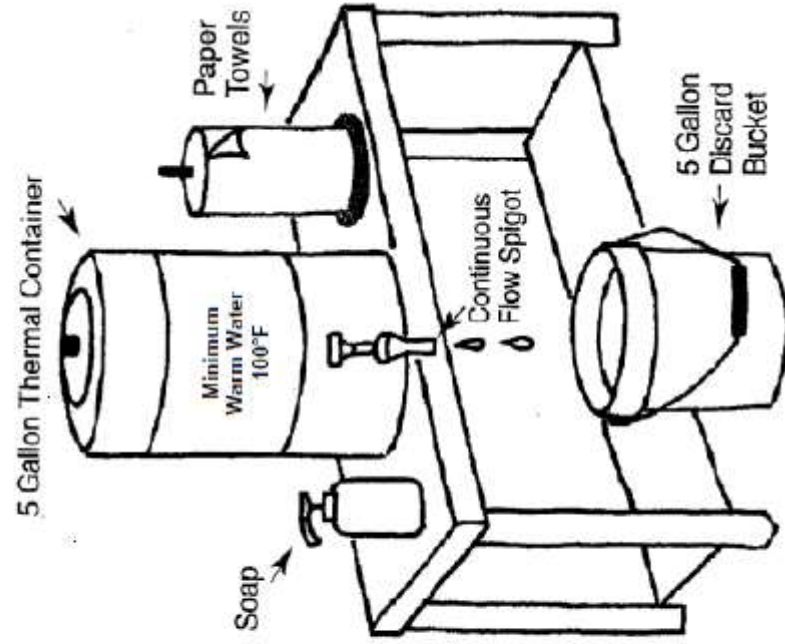

← **\*\*REQUIRED AT EACH  
FOOD PREPARATION, OPEN FOOD  
SAMPLING & BEER/SPIRITS BOOTH\*\***

The temporary hand washing station shall consist of at least a 5-gallon insulated container with hands free spigot that provides a continuous flow of warm potable water (minimum of 100°F), liquid soap in a pump dispenser, single use paper towels and a 5-gallon bucket to collect the dirty water.