

Number	FF.1
Section	Automatic Transmission
Sheet	1 (of 1)
Date	May, 1960

TORQUE CONVERTER SETSCREWS

(All Automatic Transmission Models)

Torque converters are now secured to the drive plate with longer setscrews (Part number C.16682). To ensure full engagement of the longer thread, a cut-a-way is machined in the torque converter below each threaded hole as indicated by the arrow in Fig.2.

Note that it is ABSOLUTELY ESSENTIAL that the long setscrews which are $17/32"$ (13.5 mm) in length (see inset in Fig.2.) are not fitted to a torque converter which does not have cut-a-ways machined under the setscrew holes, otherwise the setscrews will bottom in the holes. A torque converter without the cut-a-way is illustrated in Fig.1; the $7/16"$ (11.1 mm) long setscrew which MUST be fitted to this type of converter is shown inset.

In future, all converters supplied from Jaguar Spares Division will have the correct setscrews attached.

The part number of the Torque Converters with cut-a-ways are as follows:-

	Part Number
2.4 litre model	C.17080 (supersedes C.13773)
All models except 2.4 litre	C.17085 (supersedes C.10986)

Continued...

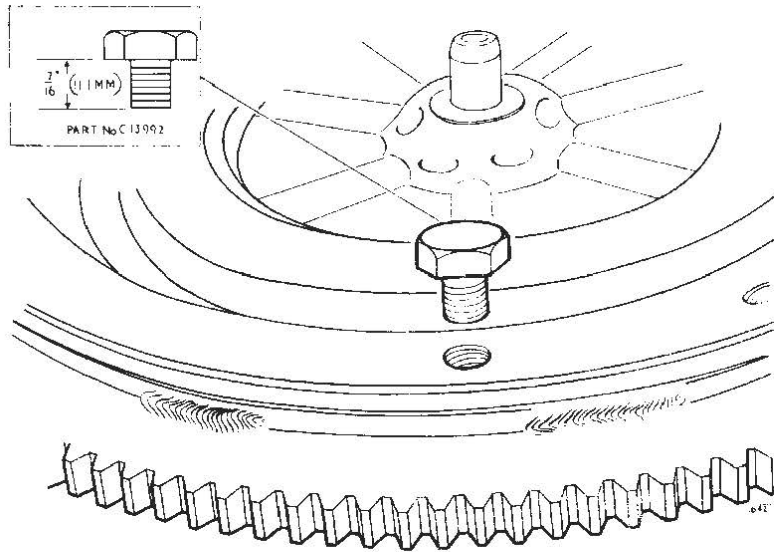

FIG 1

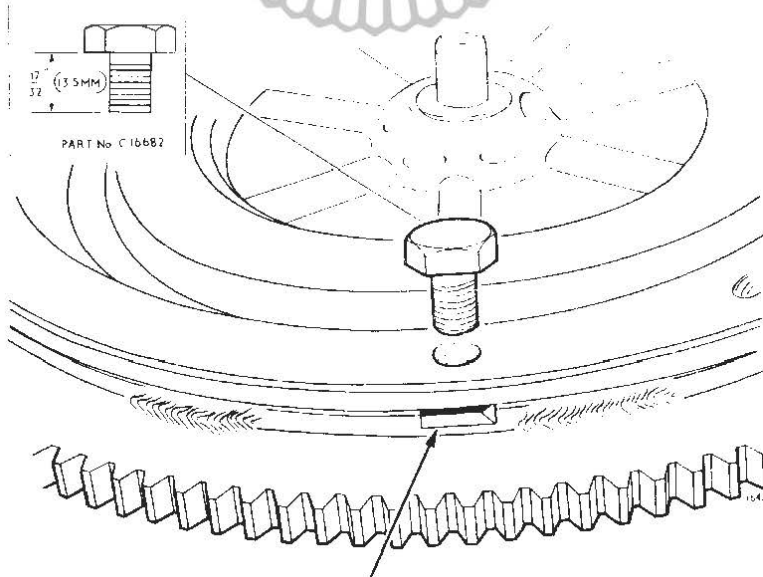

FIG 2

Number FF.2
Section Automatic Transmission

Sheet 1 (of 1)
Date February, 1961

DELETION OF MULTIPLE DISC CLUTCH BLEED VALVE
(All Automatic Transmission Models)

With effect from November, 1960 the bleed valve at the bottom of the multiple disc clutch cylinder in the low drum is omitted.

The omission of the bleed valve does not affect the operation of the transmission. The two types of front sun gear and low drum assemblies with and without bleed valve are therefore interchangeable and the part number is unchanged.



Number FF.3
 Section Automatic
 Transmission
 Sheet 1 (of 1)
 Date June, 1961

AUTOMATIC TRANSMISSION DIPSTICK

<u>Models affected</u>	<u>Commencing Chassis Numbers</u>	
	R.H. Drive	L.H. Drive
3.4 litre Mark 2 Automatic Transmission	155965	177304
3.8 litre Mark 2 Automatic Transmission	205364	217573

On cars with the above chassis numbers and onwards the automatic transmission oil level dipstick is located on the right hand side of the engine at the front of the inlet manifold. The method of checking the oil level is the same as with the previous type of dipstick as described in Service Bulletin number 266.

WARRANTY -- BORG-WARNER TRANSMISSION AND CONVERTER UNITS

Distributors and Dealers will be aware that to date warranty for Borg-Warner converters and transmission units has been limited by Borg-Warner Limited to six months or 6,000 miles, but concessions have, in fact, been given beyond this specified period in line with the standard six months warranty given by Jaguar Cars Limited.

Please note that by agreement with Borg-Warner Limited as from the 1st July, 1961 it will be possible to provide improved warranty conditions for Borg-Warner converters and transmissions, for which similar warranty to that covering Jaguar cars will be given, with the exception that warranty terms will be extended where trouble is experienced with a converter or transmission unit on a car over six months but not exceeding 12 months old, providing the mileage does not exceed 12,000.

Number FF.4.
Section Automatic
Transmission
Sheet 1 (of 1)
Date August, 1961.

MODIFIED INTERMEDIATE SPEED HOLD AND REAR PUMP

<u>Models affected</u>	<u>Commencing Chassis Numbers</u>	
	R.H.Drive	L.H.Drive
3.4 litre Mark 2 Automatic Transmission	155965	177804
3.8 litre Mark 2 Automatic Transmission	205364	217573

On cars with the above chassis numbers and onwards the rear pump housing is modified. The intermediate speed hold solenoid plunger is now contained within the rear pump housing and not in an external tube as shown in Fig. 30, Page S.48 of the Automatic Transmission Service Manual Supplement.

This modification renders certain of the rear pump and intermediate speed hold parts non-interchangeable.

For the parts breakdown of this modification see Spares Bulletin number E.11.

Number FF.5.
Section Automatic
Transmission
Sheet 1 (of 1)
Date February, 1962

MAINSHAFT RECONDITIONING SERVICE

(All models fitted with Automatic Transmission)

A reconditioning scheme for Automatic Transmission mainshafts has been introduced.

This scheme will apply only to those Mainshafts in which the Lubricating Valve has become inoperative, this being the usual reason for changing the Mainshaft. To qualify for the special exchange price applying to the scheme, all returned Mainshafts must satisfy the following conditions.

- (1) An inoperative Lubricating Valve shall be the only qualification for a Mainshaft to participate in the reconditioning scheme.
- (2) Mainshafts must be free from rust and undamaged externally. Damage caused to a displaced shaft whilst in transit will result in the reconditioned Shaft being charged at full retail price. It is therefore recommended that the displaced Mainshaft shall be returned in the package in which the reconditioned Shaft was supplied.

Reconditioned Mainshafts are obtainable from Jaguar Spares Division to Part Number 3631/R. When a reconditioned Mainshaft is ordered, it will initially be charged at the full retail price of £15 pending the return of the displaced Shaft and subsequent notification by the manufacturers of its suitability for reconditioning. Immediately such notification is received, a Credit Note will be issued to adjust the initial charge to the exchange price of £2. 10. 6d.

Number FF.6.
Section Automatic Transmission

Sheet 1 (of 1)
Date April, 1962

SERVO CYLINDER SEALING RING

On all Borg Warner automatic transmission units now being fitted to current production models, a copper sealing ring (Part No. 9204) is fitted to the servo cylinder bolts. The sealing ring is to prevent oil seepage along the threads of the bolts and is fitted between the spring washer and the servo cylinder. The side of the washer with the smaller hole is fitted against the spring washer.

Spares Bulletin number E.15 refers.



Number FF.7.

Section Automatic Transmission

Sheet 1. (of 1)

Date October, 1962.

MODIFIED MANUAL SELECTOR CABLE

Model affected

Commencing Chassis Number

Mark 10

R.H.Drive

301017

Commencing at the above chassis numbers all R.H.Drive Mark 10 automatic transmission cars are fitted with a modified selector cable and selector lever control rod bracket. The selector cable now has a ball joint and collet at the top end, similar to that at the lower end.

Provided both the new cable and selector rod bracket are used, it will be possible to interchange with the previous type of cable.

The adjustment of the selector cable will not be affected; however, it is now possible to adjust the cable from inside the car instead of at the transmission end.

Spares Bulletin No: L.27 refers.

SELECTING P (PARK) WHEN REVERSING

WARNING

(All Automatic Transmission Models)

It is pointed out that, due to the reverse rotation of the rear pump, the parking pawl hydraulic interlock does not operate in R (Reverse).

It is, therefore, ESSENTIAL that the P (Park) position is not selected whilst the car is moving in Reverse otherwise the parking pawl may be broken off. Always bring the car to a stop and apply the handbrake firmly before selecting P.

Will Distributors and Dealers please bring this matter to the notice of owners who have automatic transmission models.

Number FF.8

Section Automatic Transmission.

Sheet 1 (of 1)

Date October, 1962.

STICKING FORWARD SERVO

Attention is again drawn to the following symptoms of a sticking forward servo, as cases have come to our notice of incorrect diagnosis of this trouble.

1. Car drives forward in N (Neutral).
2. Transmission drags in R (Reverse).

Normal operation in D (Drive) and L (Low) positions.

Action

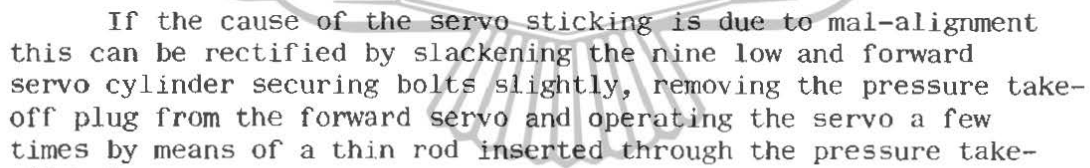

If the cause of the servo sticking is due to mal-alignment this can be rectified by slackening the nine low and forward servo cylinder securing bolts slightly, removing the pressure take-off plug from the forward servo and operating the servo a few times by means of a thin rod inserted through the pressure take-off hole.

The servo cylinder bolts should then be tightened to a torque of 15 to 18 lbs ft. (2.07 to 2.48 kgm) and the pressure take-off plug replaced.

If this procedure does not effect a cure, the low and forward servo cylinder should be removed and if there are no burrs or ragged edges on the outside diameter of the forward servo piston the low and forward servo assembly should be changed.

Number FF.9.

Section Automatic Transmission.

Sheet 1 (of 2)

Date March, 1963.

REVISED FAULT DIAGNOSIS

(Mark 2 and Mark 10 Models)

Recently numerous cases of incorrect diagnosis on the Borg Warner model D.G. transmission have been noticed, often resulting in high repair costs and considerable loss of customer goodwill.

For ease of reference, we have grouped the relevant information in P-N-D-L-R sequence and this information should be brought to the attention of personnel dealing with these units.

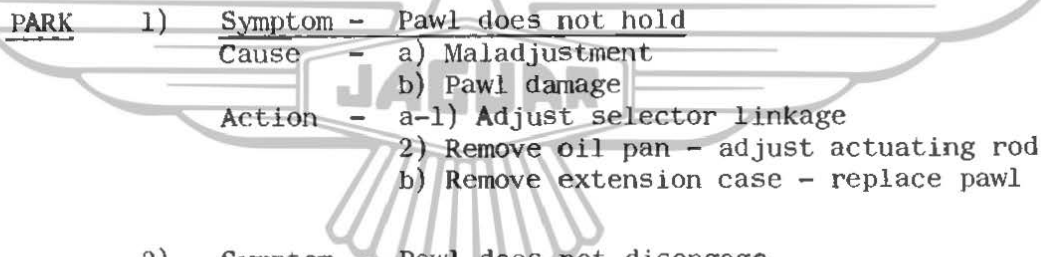
- 
- PARK 1) Symptom - Pawl does not hold
 Cause - a) Maladjustment
 b) Pawl damage
 Action - a-1) Adjust selector linkage
 2) Remove oil pan - adjust actuating rod
 b) Remove extension case - replace pawl
- 2) Symptom - Pawl does not disengage
 Cause - a) Incorrect procedure
 b) Linkage maladjustment
 Action - a) Follow procedure given on page S.45 of the
 Automatic Transmission Service Manual and in
 the Operating Handbooks.
 b) Adjust selector linkage
- NEUTRAL 3) Symptom - Drives in 1st gear in Neutral, transmission
 drags in R
 Cause - Forward servo sticking
 Action - 1) Remove servo and outer piston, polish servo
 bore and piston
 2) Renew piston lip seal
 3) Inspect intermediate plate for burrs or
 distortion, ream if necessary
 4) Align servo outer cylinder with the aid of
 band adjusting tool

/cont'd.....

DRIVE

- 4) Symptom - Inoperative in D or any other selector position, no leakage, final drive O.K.
Cause - a) Selector linkage disconnected
b) Main relief valve stuck open
Action - a) Reconnect selector linkage
b-1) Push car, select D for direct drive at 30 m.p.h. and endeavour to free valve by repeatedly selecting L
b-2) Remove oil pan and valve body, free main relief valve.
- 5) Symptom - Slip or rough on take-off.
Cause - Fluid level low by more than 2 pints, suspect leakage
Action - 1) Top up fluid level
2) Rectify any leakage immediately
3) Check forward band adjustment
- 6) Symptom - Will not take-off on hills, engine labours
Cause - Converter stator freewheel slips or collector ring nose piece fractured ("Milled" off by dropped converter thrust washer)
Action - Check stall speed; if below 1000, renew converter and/or collector ring
- 7) Symptom - No upchanges from 1st gear, possibly speedo not working
Cause - Governor and/or valve defective
Action - Remove extension case only, replace damaged parts
- 8) Symptom - Upshift or downshift speeds incorrect
Cause - a) If regularly below or above normal: accelerator linkage maladjusted, governor binding on shaft or governor adjusting screw interfered with
b) If irregular: governor bushing loose in extension case
Action - a) Adjust accelerator linkage or governor adjusting screw to obtain correct shift speed figures, suspect governor shaft
b) Remove extension case only, fit oversize bushing if available, using a press
- 9) Symptom - "Soft" 1-2 shift
Cause - Multi disc clutch plates worn, piston ring seized
Action - Remove gearbox only, renew clutch pack, also oil seals on front sun gear and inside ring gear extension. Inspect piston and ring. Air pressure check before installation.

/cont'd....

- 10) Symptom - Shifts 1-2, misses 2nd gear
 Cause - Multi disc clutch inoperative, possibly snap ring dislodged
 Action - Remove gearbox only, renew clutch pack and damaged parts. Inspect piston and ring. Air pressure check before installation
- 11) Symptom - Will not shift 2-3 or only when releasing accelerator
 Cause - a) 2nd speed hold defective
 b) Transfer tube omitted or incorrectly installed
 c) High converter pressure, over 120 p.s.i. in R
 d) Direct drive clutch driven plate damaged or glazed
 e) Direct drive clutch damper spring(s) fractured - metal paste in oil pan
 f) Governor valve stuck or governor bushing loose
 Action - a) Overhaul 2nd speed hold mechanism
 b) Remove gearbox, correctly install transfer tube
 c) Suspect lubrication valve obstructed, test with pressure oilcan fit reconditioned mainshaft if necessary, also replace converter assembly
 d) If direct drive clutch and converter pressure normal and no metal paste or other deposit in oil pan fluid, car may be used without further remedial action
 e) Replace converter, completely strip gearbox and clean thoroughly
 f) Verify by direct drive clutch pressure check - overhaul extension case
- 12) Symptom - Severe overheating of transmission, fluid boils, maximum speed reduced by 30-50 m.p.h.
 Cause - Converter stator freewheel seized - do not run car in this condition!
 Action - 1) Replace converter
 2) Check gearbox for overheating
 3) If overheating was not prolonged, overhaul gearbox with new rubber seals and O-rings
- 13) Symptom - Severe judder and noise in 3rd gear at speeds of 2nd gear (20-70 m.p.h. approximately)
 Cause - Forward drum bushing seizing on rear sun gear, possibly intermittent

/cont'd.....

- Action - 1) Remove gearbox only, replace forward drum and rear sun gear
2) Investigate cause of seizure:
a) Lubrication valve obstructed (if direct drive affected, also replace converter assembly)
b) Forward drum overheated by slip due to prolonged low fluid level (leakage)
c) Forward band dislocated due to strut fouling band

LOW

- 14) Symptom - Operates only in L, or in D over 30 m.p.h.
Cause - Reverse freewheel failed or low drum plate dowels dislocated
Action - Remove gearbox only, inspect freewheel and low drum plate retention; check closed gap of snap ring.

REVERSE

- 15) Symptom - Will not reverse - engine labours
Cause - a) If normal on level road and does not drive in N (i.e. labours on gradient only):
converter stator freewheel slips or collector ring nose piece fractured
b) If engine labours on level road and car drives forward in N: forward servo sticking, (see fault in Neutral) or multi-disc clutch seized
Action - a) Replace converter and/or collector ring
b) Overhaul forward servo as for fault 3 - inspect multi disc clutch
- 16) Symptom - Reverse gear disengages or inoperative - transmission cold
Cause - Rear pump ball check valve leaking
Action - Remove oil pan and valve body, replace intermediate plate
- 17) Symptom - Operating only in R
Cause - End of selector valve broken off
Action - Remove oil pan and valve body, replace selector valve

Number FF.10.
Section Automatic Transmission.

Sheet 1 (of 1)
Date May, 1963.

SHIPMENT OF TRANSMISSION UNITS FOR RECONDITIONING.

All Distributors and Dealers are reminded that they are responsible for the shipping charges incurred when returning torque converters and gearboxes under guarantee to the factory.

Distributors and Dealers are also responsible for the freight charges incurred on both outward and inward consignments of converters and gearboxes returned to Borg - Warner for reconditioning. This also includes import duties, insurance and incidental charges.

Shipment charges will not be accepted by either the Transmission Manufacturer or this Company.

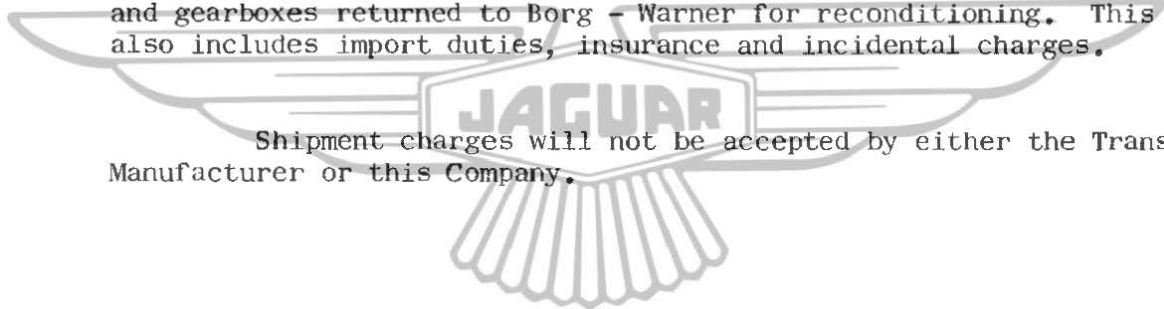

Number FF.12.
Section Automatic Transmission.

Sheet 1 (of 1)
Date June, 1964.

SHELL DONAX T6 AUTOMATIC TRANSMISSION FLUID.

(All models)

Future supplies of the Donax T6 Automatic Transmission Fluid manufactured by Shell may be found to be red in colour.

The physical and chemical characteristics of this fluid are similar to the previous type and it is permissible to mix the two fluids.



Number FF.12 (2nd issue)
Section Automatic Transmission.

Sheet 1 (of 1)

Date December, 1964.

This Service Bulletin supersedes the original issue of June, 1964 which should be destroyed.

SHELL DONAX T6 AUTOMATIC TRANSMISSION FLUID.

(All models)

Future supplies of the Donax T6 Automatic Transmission Fluid manufactured by Shell may be found to be red in colour.

The physical and chemical characteristics of this fluid are similar to the previous type and it is permissible to mix the two fluids.

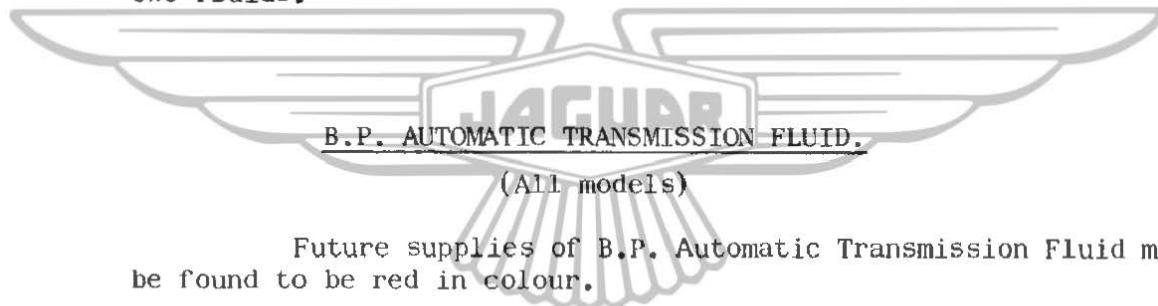

B.P. AUTOMATIC TRANSMISSION FLUID.

(All models)

Future supplies of B.P. Automatic Transmission Fluid may be found to be red in colour.

The physical and chemical characteristics of this fluid are similar to the previous type and it is permissible to mix the two fluids.

Number FF.14.
Section Automatic Transmission.

Sheet 1 (of 1)
Date June, 1965.

PAPER PLATE TORQUE CONVERTER.

Models affected.

Commencing engine numbers.

3.4 litre Mark 2	KJ.6901
3.8 litre Mark 2	LE.2062
3.4 'S' Type	7B.3557
3.8 'S' Type	7B.55557

A modified automatic transmission unit (Part number C.25615) and torque converter assembly (Part number C.23447) has been introduced in production to give an improved quality of gear shift.

The new transmission unit has a modified converter shuttle reverse valve and three additional multi-disc clutch return springs. The new torque converter assembly has a direct drive clutch with paper facings and an improved technique is used in balancing the assembly.

To obtain the improved gear shift the transmission units and torque converters must be used in paired assemblies and not with the original type of transmission unit or converter.

IMPORTANT.

The previous type torque converter (Part number C.17085 or C.10986) must under no circumstances be fitted to latest type automatic transmission unit.

Identification

Both the new automatic transmission unit and torque converter are identified by a suffix 'P' after their respective serial numbers. The torque converter serial number is stamped on the flat face of the converter inboard of the ring for the drive plate bolts.

Pressures.

The nominal converter pressure with this new arrangement is increased by 5 lb/in² (0,35 kg/cm²).

/cont'd.....

Modifying previous type Transmission.

On cars prior to the above numbers the shift quality can be improved by fitting the following modified parts to the valve block IN CONJUNCTION WITH A PAPER PLATE TORQUE CONVERTER (Part number C.23447). Unless the transmission unit is being stripped for other reasons the three additional multi-disc return springs need not be fitted.

Parts required.

10271 (20-6413)	Converter shuttle reverse valve
C.23447	Torque converter (paper plate type).



Number FF.19
Section Automatic Transmission

Page 1 of 1
Date July, 1968

REAR BAND ADJUSTMENT

Revised figures are now advised for rear band adjustment for the Model 35 range of Automatic Transmission Units fitted with the 7/16" (11.1 mm.) diameter adjusting screws as follows:-

- (1) Slacken the locknut and tighten the band adjusting screw to a torque of 10lb./ft. (1.38 kg.m.), using a torque wrench and an adaptor.
- (2) Back off the adjusting screw $\frac{3}{4}$ to $\frac{7}{8}$ of a turn and, holding the adjusting screw, tighten the locknut with a box spanner.

NOTE: These revised figures do NOT apply to the early model 35 Transmission unit with the smaller diameter adjusting screw.

When the rear clutch is stripped, the clutch piston spring seat should be checked and if the two faces are not in line within .020" (.508 mm.) should be discarded and replaced with a part that is correct to drawing.

This may be obtained from JAGUAR SPARES DIVISION, COVENTRY, under Part Number 9806.

Due to tolerance stack-ups, it is extremely unlikely that this fault would become apparent on transmissions having 3 or 4 plate rear clutches. However, if such a unit is being stripped for any reason, this part should be checked and replaced if required.

IT IS EMPHASISED THAT THERE IS NO SAFETY PROBLEM involved in this fault, and that this bulletin is issued to assist Distributors and Dealers in the diagnosis of any unusual rear clutch failures which may occur.



Number FF.21
Section Automatic Transmission

Page 1 of 2
Date July, 1968

FAULTY REAR CLUTCH SPRING SEAT
(Model 35 and 35F Automatic Transmission Units)
240-340, 3.4-3.8 Litre 'S' Type
3.4-3.8 Mark 2 (Later cars)

Information has been received from the Manufacturers of the Automatic transmission unit to the effect that some of the above units have been built with a dimensionally faulty rear clutch piston spring seat.

The fault is best described by reference to the sketches below.

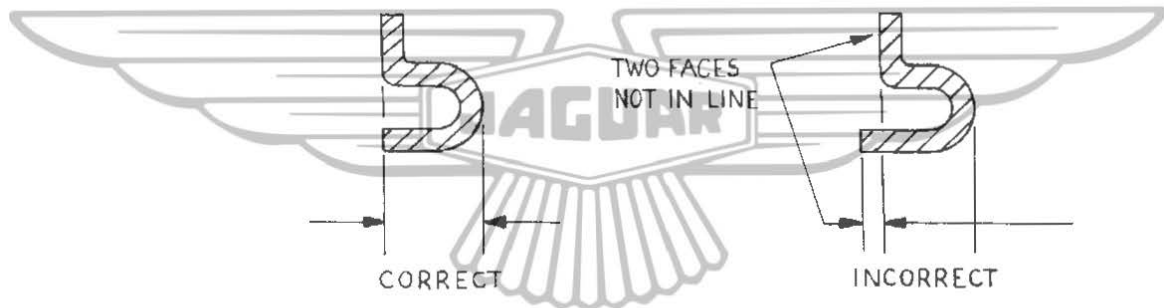

The effect of this fault is to reduce the length in which the rear clutch spring has to operate, which, under adverse tolerance conditions of all the rear clutch components, can allow the spring to become solid before the rear clutch is fully engaged.

The symptoms of the fault are, therefore, any or all of the following:-

1. Soft 2 - 3 shift.
2. Breakaway on 5 - 2 shift.
3. Judder or clutch squawk in reverse.

It should be remembered that there are, of course, many other possible reasons for any or all of the above faults, and careful checks should be made that all other relevant components are operating correctly.

Number FF.23
Section Automatic Transmission

Page 1 of 1
Date April, 1969

AUTOMATIC TRANSMISSION FLUID

A new fluid for use in Automatic Transmission Units is now being marketed by the various Oil Companies to specification M2C 33F.

The new fluid has improved frictional characteristics and is approved for use in all Automatic Transmission and Power Assisted Steering Units fitted to Jaguar cars. The new fluid is miscible with the previous Type A Suffix A brand and it will therefore not be necessary to drain units when topping up becomes necessary. It is, of course, preferred that the new M2C 33F fluid should be used whenever possible.

The brand names of the new fluid are shown below:-

<u>Oil Company</u>	<u>Original Fluid</u>	<u>New Fluid</u>
Mobil	Mobilfluid 200	A.T.F.210
Castrol	Castro T.Q.	T.Q.F.
Shell	Donax T.6	Donax T.7
Esso	Auto. Trans. fluid	Esso Glide
B.P.	Auto. Trans. Type A	Autran B
Duckham	Nolmatic	Nolmatic
Regent	Texamatic fluid	Texamatic 6991 Type F

Number FF.24

Section Automatic Transmission

Page 1 of 1

Date June, 1969

AUTOMATIC TRANSMISSION FLUID

Please note a further amendment to the changes of Automatic Transmission Fluid advised in Service Bulletin FF.23.

Messrs. Duckham have modified their product to conform to specification M2C-33F and this will be marketed under the name Q-MATIC. The new Q-matic fluid is miscible with the previous Nomatic and Distributors and Dealers are requested to amend Bulletin FF.23 accordingly.